

The durability of the Avery Weigh-Tronix Forklift Truck Scale is immediately apparent. The scale's patented design features a heavy-duty carriage comprised of two solid metal plates. The plates are coupled together by application-designed Weigh Bar weight sensors.

The Weigh Bars electronically measure the load on the forks and convey this information to a summing and angle detection box. The box is constructed of stainless steel and placed between two metal plates for added protection.

The Weigh Bar cables are enclosed within metal guards for environmental protection. Travel stops are even built into the scale to prevent forks from sliding off either side.

The entire carriage assembly is primed and finished with a durable epoxy paint.

Maximum Capacities/Model

2500 kg (5,000 lb)	
5000 kg (10,000 lb)	

Overload Protection

 Withstands up to 200% of full capacity applied anywhere up to 635 mm from frame and side loads up to 100% of full capacity.

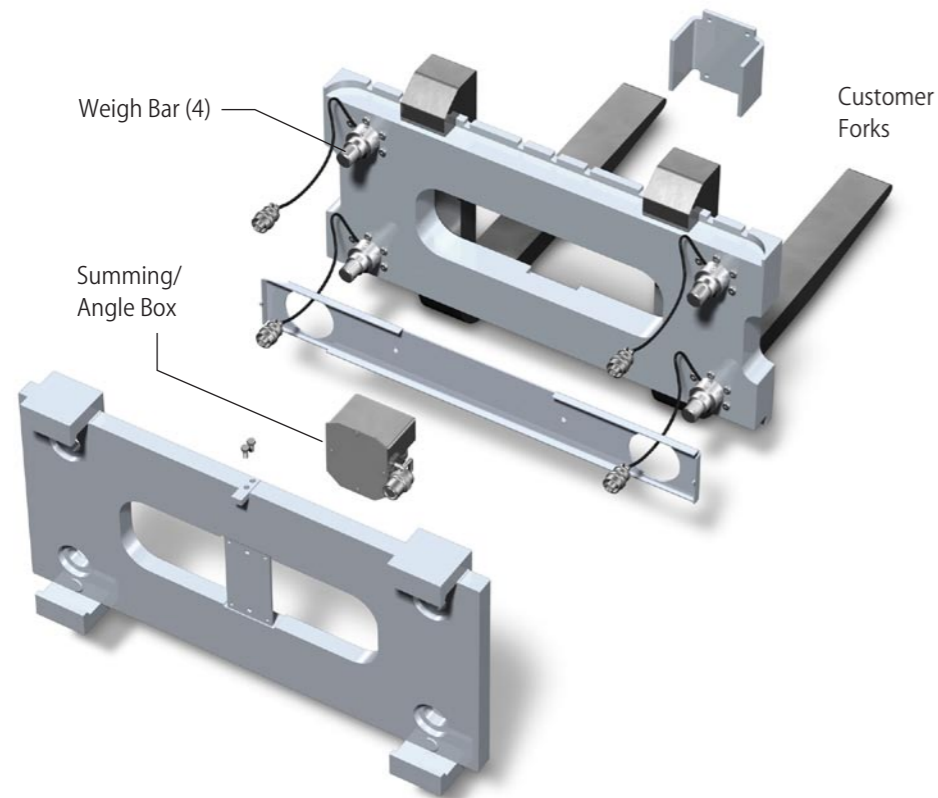

Forklift Truck Scale

LOADED FOR PROFITABILITY

Avery Weigh-Tronix

© Avery Weigh-Tronix, LLC 2005. All rights reserved. This publication is issued to provide outline information only which, unless agreed by Avery Weigh-Tronix, LLC in writing, may not be regarded as a representation relating to the products or services covered. Avery Weigh-Tronix, LLC reserves the right to alter without notice the specification, design, price or condition of supply of any product or service.

Weigh Bar® is a registered trademark of Avery Weigh-Tronix, LLC
Windows® is a registered trademark of Microsoft Corporation.

Forklift Truck Scale/3_05/Issue1 Liftruck_L.indd (C&D)

Avery Weigh-Tronix, LLC
Foundry Lane, Smethwick,
West Midlands, England B66 2LP.
Tel: +44 (0)870 90 34343
Fax: +44 (0)121-224 8183



E mail: info@awtxglobal.com
Internet: <http://www.averyweigh-tronix.com>

Why use a forklift truck scale?

In many operations, weighing is considered an extra step that takes too much time. It is easier to guess the weight than to make a trip to a scale. That guesswork costs manufacturers, shippers and other businesses millions in revenue every year.

Accurate confirmation of documented weights is the most productive way to ensure precise inventory management – whether you receive, ship or move goods.

Add an Avery Weigh-Tronix scale to your forklift trucks and you can seamlessly integrate weighing and data management into your operation – without adding any extra steps.

Avery Weigh-Tronix Forklift Truck Scales were specifically developed for industrial/commercial applications and incorporate design features to weigh accurately under all conditions.



Loaded for Profitability

Incoming Goods Verification - confirm that the quantities you ordered are the quantities you receive at the point of unloading. There are no extra steps involved.

Shipping - verify the accuracy of your customers' estimated shipping weights. Correct the billing charges when you find a different weight.

Stock Management - help track inventories and save steps as product flows between departments. Instantly document material weights as they are picked up for transport. No costly guess work, no extra trips to a remote platform scale.

Compliance - use the instant weight data to load evenly and safely. Avoid overload fines and unsafe operations.

System Compatibility - designed for use with all ITA Class II and Class III cleat type forklift trucks. Available in a range of carriage widths.

Loaded with Design Features

- Front and rear sections of the carriage assembly are linked by our patented Weigh Bar® weight sensors, eliminating the need for flexures
- Two large viewing ports give the operator a clear line of sight to the forks
- No moving parts, electromechanical devices or hydraulics to adjust

Loaded for Quick Installation

- Mounts on any make of forklift truck
- Delivered fully calibrated from factory
- No welding required

Loaded for Unsurpassed Accuracy

Our patented Weigh Bar weight sensors and auto level (out-of-line) sensor deliver the highest accuracy even when:

- Fork positions change
- Wheels are on uneven surfaces
- Mast is tilted

Material can be placed anywhere on the forks without affecting accuracy.

Loaded for Strength

- Solid steel carriage assembly for superior durability, reliability and accuracy
- Electronics housed in stainless steel enclosure
- This reduces downtime and increases productivity



Instrumentation to match your application

Choice of two models for direct operation or integrated network operations

WI-125

Practical, no-nonsense operation

- Simple operation
- Plastic and impact-resistant enclosure with smooth rounded corners for driver safety
- Automated backlight LCD display for low-light environments
- RS232 serial port for easy connection to printer for weight documentation
- Six annunciators: gross, net, center of zero, print, lb, kg



SimulCast™ WI-130

Advanced Data Management

Loaded with features

- Durable Stainless Steel Enclosure
- Fully programmable
- Supports extensive number of peripherals: bar code scanner, printer, computer, infra red transceiver, radio frequency transceiver
- Clear, visible information via graphic display
 - Simple step-by-step operating instructions
 - Programmable function keys and numeric pad
- Displays key information simultaneously:
 - Weight
 - Pro or shipment number
 - Accumulated weight
 - Accumulated skids/pallets

Faster, easier data management collection



Capable of storing more than 750 records in battery protected memory

Developed specifically for the forklift truck scale industry to store:

- ID number
- Employee ID
- Accumulated weight
- Accumulated skids/pallets
- Estimated weight
- And much more, including custom data for your needs

Transfer data to

- On-board printer
- Mainframe, AS400, UNIX/Linux System, or Windows® host device

Transfer data to host device via

- Hardwire
- Infra red
- Radio frequency
- Ethernet
- Network connections