

# Suspended Scales

MECHANICAL



- robust
- accurate
- reliable
- portable
- low cost
- easy to read
- corrosion resistant
- capacities from 5 kg - 300 kg

# Suspended Scales

## Model 235 6S

Compact, robust and corrosion resistant, 150 mm diameter dial housed in a tough ABS plastic case with shatterproof polycarbonate dial cover. Low friction acetal bearings provide positive movement to give maximum sensitivity. Accurate to one part in 250 with up to 15% zero adjustment. Supplied with top and bottom hook.

### Option

Oblong pan (5 kg only).

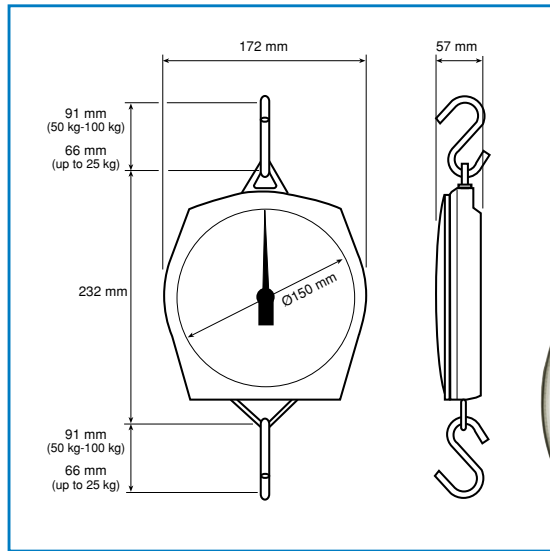

### Metric

5 kg x 20 g  
10 kg x 50 g  
25 kg x 100 g  
50 kg x 200 g  
100 kg x 500 g

### Dual marked

5 kg x 20 g / 11 lb x 1 oz  
10 kg x 50 g / 22 lb x 2 oz  
25 kg x 100 g / 55 lb x 4 oz  
50 kg x 200 g / 110 lb x 8 oz  
100 kg x 500 g / 220 lb x 1 lb

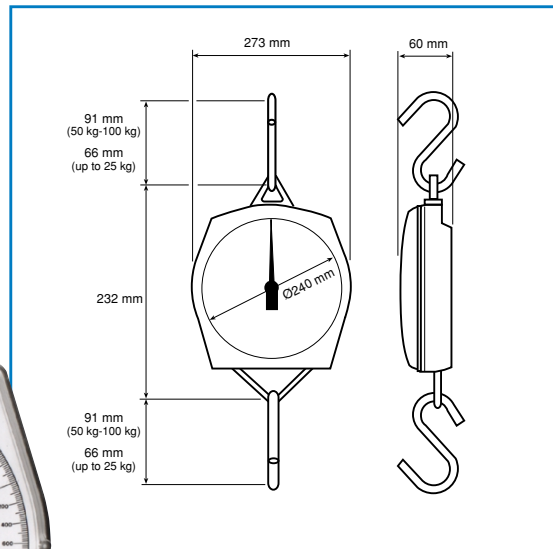

## Model 235 10S

Robust and corrosion resistant, large easy to read 254 mm diameter dial housed in a tough ABS plastic case with a shatterproof polycarbonate dial cover. Low friction bearings provide positive movement to give maximum sensitivity. Accurate to one part in 500 with up to 15% zero adjust. Supplied with top and bottom hooks.

### Option

Oblong pan (5 kg only).

### Metric

5 kg x 10 g  
10 kg x 20 g  
25 kg x 50 g  
50 kg x 100 g  
100 kg x 200 g

# MECHANICAL

## Model 235 6M

Compact and robust, 150 mm diameter dial housed in the traditional metal case. Accurate to one part in 250 with up to 15% zero adjustment. Supplied with top and bottom hooks

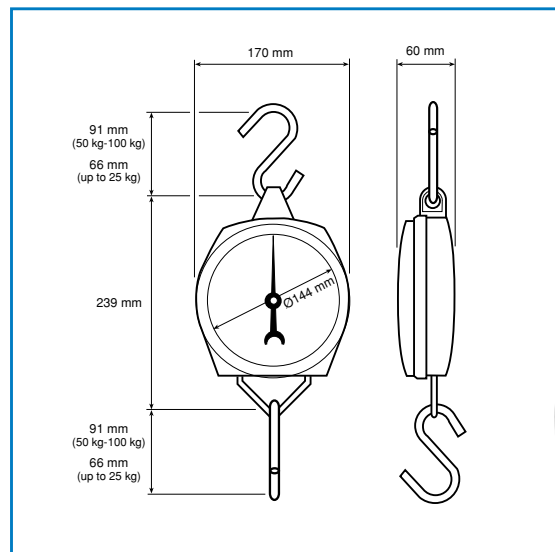

### Metric

5 kg	x	20 g
10 kg	x	50 g
25 kg	x	100 g
50 kg	x	200 g
100 kg	x	500 g

### Dual marked

5 kg	x	20 g	/	11 lb	x	1 oz
10 kg	x	50 g	/	22 lb	x	2 oz
25 kg	x	100 g	/	55 lb	x	4 oz
50 kg	x	200 g	/	110 lb	x	8 oz
100 kg	x	500 g	/	220 lb	x	1 lb

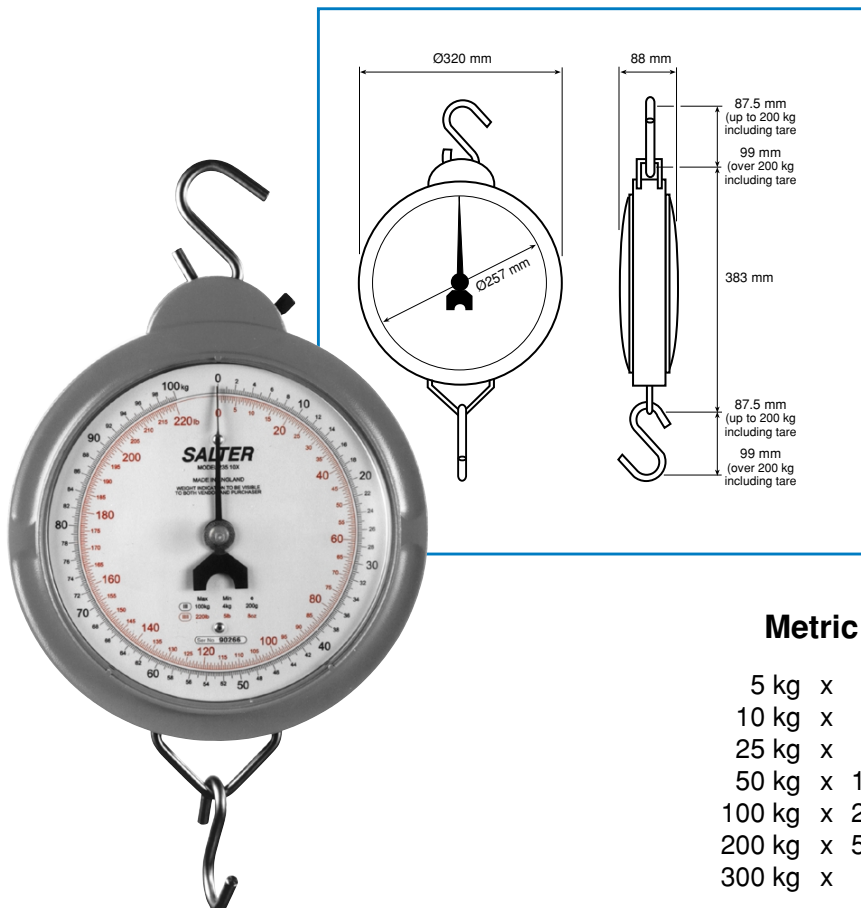

## Model 235 10X (Trade & Non-Trade)

Heavy duty suspended scale, Eu trade approved up to 100 kg. 254 mm diameter easy to read dial housed in a robust grey die cast casing with low friction bearings providing positive movement to give maximum sensitivity. Accurate up to one part in 1000 trade, One part in 500, non-trade. Supplied with top and bottom hooks as standard. Double dial versions available, metric only, or up to 50 kg, dual marked.

### Option

Swivel bottom hook.  
Double lipped scoop (5 kg/10 kg only)

### Metric

5 kg	x	10 g
10 kg	x	20 g
25 kg	x	50 g
50 kg	x	100 g
100 kg	x	200 g
200 kg	x	500 g
300 kg	x	1 kg

### Dual marked

5 kg	x	10 g	/	11 lb	x	1/2 oz
10 kg	x	20 g	/	22 lb	x	1 oz
25 kg	x	50 g	/	56 lb	x	2 oz
50 kg	x	100 g	/	110 lb	x	4 oz
100 kg	x	200 g	/	220 lb	x	8 oz
200 kg	x	500 g	/	440 lb	x	1 lb
300 kg	x	1 kg	/	660 lb	x	2 lb

# Suspended Scales

## MECHANICAL



**5 kg oblong stainless steel pan**  
(Can be supplied with 235 6S & 235 10S only)

**Dual marked**

235 6S      5 kg x 20 g/11 lb x 1 oz

235 10S     5 kg x 10 g/11 lb x 1/2 oz

### 5 kg & 10 kg double lipped stainless steel scoop

Can be supplied with 235 10X

**Metric**

235 10X     5 kg x 10 g  
10 kg x 20 g

**Dual marked**

5 kg x 10 g/11 lb x 1/2 oz  
10 kg x 20 g/22 lb x 1 oz



### 10 kg & 25 kg round stainless steel pan 305 mm diameter

Can be supplied for retrofitting to the following suspended scales:

**Metric**

235 6S      10 kg x 50 g

235 6M      25 kg x 100 g

235 10S     10 kg x 20 g

235 10X     10 kg x 20 g  
(Non-trade)    25 kg x 50 g

**Dual marked**

10 kg x 50 g/22 lb x 2 oz

25 kg x 100 g/55 lb x 4 oz

10 kg x 20 g/22 lb x 1 oz



P.O. Box 9533, Smethwick, West Midlands, B66 2TE  
Tel: 0870 444 6132 Fax: 0870 010 2241  
E-mail: sales@salterbrecknell.co.uk

